

Date: May 2012

R134a REEFER HEALTH CHECK PROCESS

1. Foreword

The following process has been developed to allow for the testing of refrigerated containers at off-hire, interchange and/or pre-trip inspection. This process allows for the safe extraction of a small sample of refrigerant from the reefer machine which is then tested to ensure that the refrigerant is free from contamination.

This document has been prepared for use only by suitably qualified and experienced reefer engineers under proper supervision and direction from their own companies in relation to the routine extraction and testing of refrigerant gas from machinery in ISO shipping containers. Please refer to the end of the document in relation to legal liability.

Before proceeding, read through the complete document to ensure the process is fully understood.

1.2 Health and Safety

- No personnel are permitted inside the refrigerated container. If container doors are not sealed, a visual internal inspection should be carried out to ensure no personnel are working in the container. Doors to be closed and sealed after inspection.
- Unit must be unplugged from any electrical source.(Mains or diesel generator)
- The container must be away from electrical source, flame, static electricity or any heating source.
- Safety tape off the zone for testing and restrict access to un-authorized personnel.
- Enforce a no smoking and no naked flames zone within the test area.
- Provide a class C (dry powder) and class D fire extinguisher.
- Have available a fully charged mobile phone and a list of contacts and emergency numbers.

Document No. EMS-03 Ver 2.1	Engineering & Maintenance Services, Seaco Global Ltd. 21 St Thomas Street. London SE1 9RY Tel: +44 (0) 20 7939 5600 Fax: +44 (0) 20 7939 5650 www.seacoglobal.com	1 of 25
--------------------------------	---	---------

- Wear safety goggles, gloves, high visibility vest and safety helmet.
- Isolate controller battery-pack (if fitted).
- Visually inspect the compressor / sight glass for any unusual oil condition, activity or leakage. If found contact Seaco before carrying out the test.

IF AT ANY TIME DURING THE PROCEDURE SMOKE IS OBSERVED AT THE MACHINE OR RECOVERY/SAMPLING EQUIPMENT THE EXTRACTION / TEST MUST BE TERMINATED IMMEDIATELY.

2 Sampling / test equipment:

There are a number of simple extraction rigs being developed by container owners and depots to allow for the safe extraction of a gas sample. (See *below and appendix D*). Rigs may be designed to suit the requirements of owners or depot operational and local health and safety requirements. Seaco have trialled the rigs detailed below as well as using the 2 way gauge manifold set. Extraction from the machinery is via vacuum method and sample testing carried out either by halide flame test and/or the Refrigerant Risk Assessment (RRA) Test (tube sample testing by RAE). **See appendix C for further details of this test method.**

2.1 Tools / parts required - see appendix B

The following parts can be used to build sampling rigs and testing gear, suitable alternative parts can be sourced locally to build rigs.

- Oxygen free (dry) nitrogen bottle with regulator
- Vacuum pump
- 1 x Compound gauge
- 1 x 1/8" Female Briggs to 1/4" Male Flare Coupling
- 1 x R134a high pressure gauge line - 30cm (1ft)
- 1 x 1/4" Male Flare to 1/4" Male Flare Sight Glass (Optional)
- 1 x 1/4" Flare Swivel Coupling (Optional, with sight glass)
- 1 x R134a high pressure quick connector
- 2 x In-line ball valve - 1/4" Male to 1/4" Female Flare
- 1 x 1/4" Male Flare Union Tee

Document No. EMS-03 Ver 2.1	Engineering & Maintenance Services, Seaco Global Ltd. 21 St Thomas Street. London SE1 9RY Tel: +44 (0) 20 7939 5600 Fax: +44 (0) 20 7939 5650 www.seacoglobal.com	2 of 25
--------------------------------	---	---------

- 1 x ¼" Female Flare Union
- 2 x 1/4" female to R134a high pressure quick male connector - TK part No. 66-7179 / Carrier part No. AC302-438
- 1 x High pressure male quick connector to 1/4" male - Mitsubishi part No. SSA327B047
- 1 x Capillary tube
- Loctite 567 Thread Sealant
- Halide Torch (Figure 1 / Appendix A)
- Water container/bottle
- Refrigeration ratchet spanner

- *Note: Before setting up an extraction rig, ensure all components are in full working order and fit for purpose. Check all seals and ensure all shut off valves are fully operational. Ensure extraction rig is clean and free of contaminants before use.*

Document No. EMS-03 Ver 2.1	Engineering & Maintenance Services, Seaco Global Ltd. 21 St Thomas Street. London SE1 9RY Tel: +44 (0) 20 7939 5600 Fax: +44 (0) 20 7939 5650 www.seacoglobal.com	3 of 25
--------------------------------	---	---------

Schematic 1: Diagram of a simple extraction rig to be used to extract sample from reefer machine.

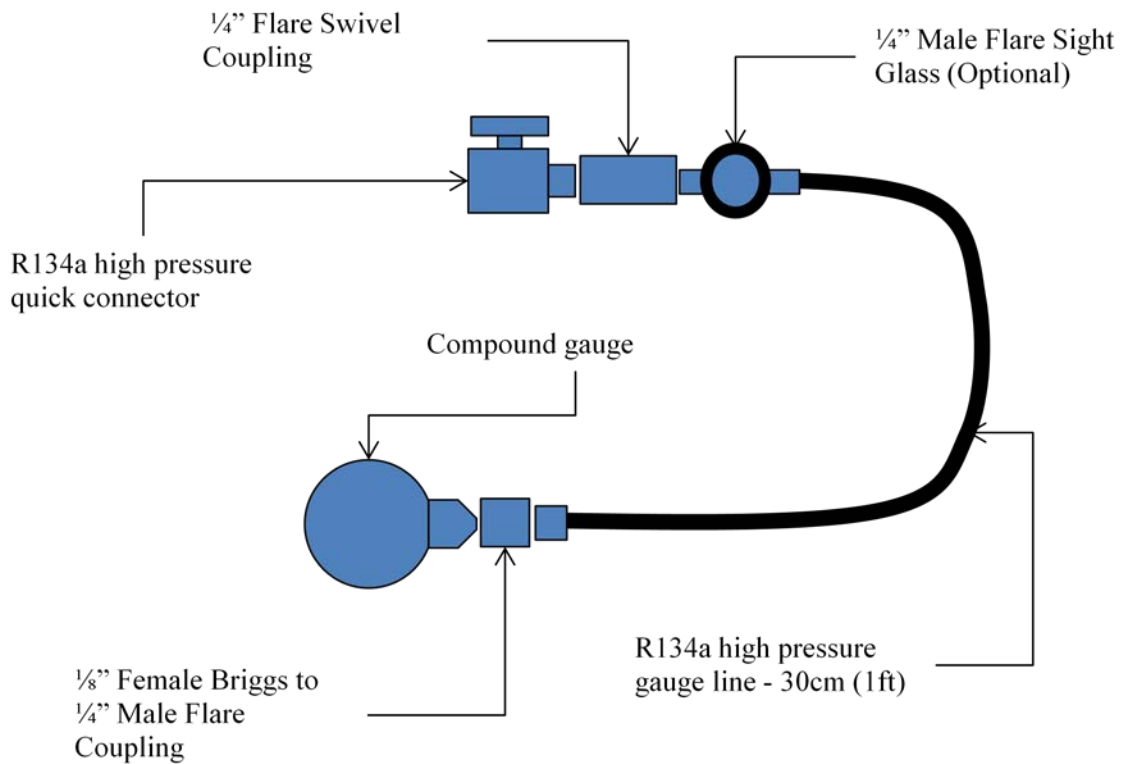

Schematic 2: Diagram of dual-purpose extraction rig to be used to extract sample from reefer machine and R134a cylinders.

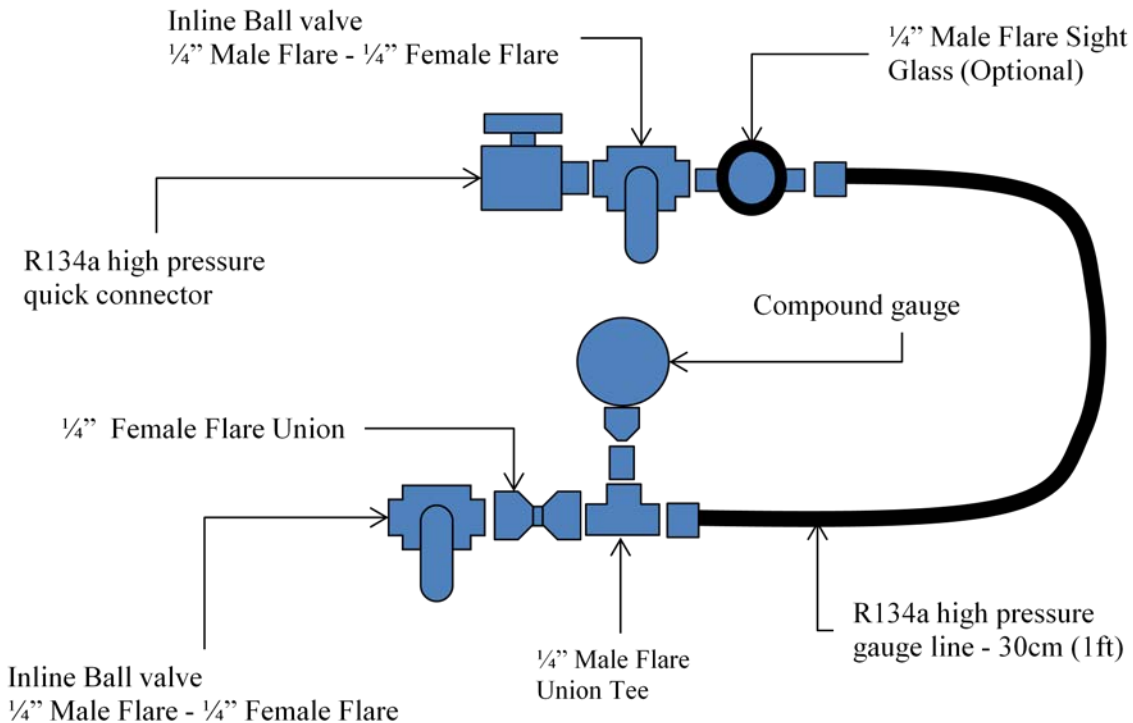

Note: an alternative extraction method is to use a manifold gauge set. It is advisable that this be a manifold set dedicated to testing to avoid cross contamination.

3 Procedure - Equipment preparation, flushing and triple evacuation

- 3.1 Prepare rig or manifold set and pressure test sampling equipment to (minimum) 7 bar (100psi) using nitrogen (see above schematics & photo A).
- 3.2 Purge nitrogen from the equipment.
- 3.3 Connect R134a high pressure quick connector to the vacuum pump as per diagram (photo B and C).

<p>Document No. EMS-03 Ver 2.1</p>	<p>Engineering & Maintenance Services, Seaco Global Ltd. 21 St Thomas Street. London SE1 9RY Tel: +44 (0) 20 7939 5600 Fax: +44 (0) 20 7939 5650 www.seacoglobal.com</p>	<p>5 of 25</p>
--	--	----------------

Photo A



Dual-Purpose Short Hose Extraction Rig (Recommended by Seaco)

Photo B



Rig connected to vacuum pump

Photo C



Photo D



1/4" female to R134a high pressure quick male connector

- 3.4 Ensure the high pressure quick connector valve is open. (If using dual-purpose rig ensure in-line ball valve A is open and in-line ball valve B is closed) Refer to schematic 2.
- 3.5 Switch on vacuum pump.
- 3.6 Evacuate rig to - 1bar (30 in Hg).
- 3.7 Shut high pressure quick connector valve. (If using dual-purpose rig ensure the in-line ball valve A is closed). Refer to schematic 2.
- 3.8 Switch off vacuum pump & disconnect rig.

The gas sampling rig is now ready to be taken to the reefer container to be tested

4 At the reefer unit, sample extraction.

- 4.1 Visually inspect the compressor / sight glass for any unusual oil condition and / or activity.
- 4.2 Remove liquid line service valve (King valve) stem cap.
- 4.3 Ensure liquid line service valve is fully back-seated.
- 4.4 Remove service port cap and connect high pressure quick connector on rig.
- 4.5 Crack open liquid line service (King) valve.
- 4.6 Open high pressure quick connector & allow pressures to equalise. (If using dual-purpose rig ensure in-line ball valve A is also open, valve B closed). Refer to schematic 2.
- 4.7 Check sight glass, if fitted, for any signs of contamination.

Document No. EMS-03 Ver 2.1	Engineering & Maintenance Services, Seaco Global Ltd. 21 St Thomas Street. London SE1 9RY Tel: +44 (0) 20 7939 5600 Fax: +44 (0) 20 7939 5650 www.seacoglobal.com	7 of 25
--------------------------------	--	---------

- 4.8 Backseat the liquid line service valve, close high pressure quick connector. (If using dual-purpose rig ensure in-line ball valve A is also closed). Refer to schematic 2.
- 4.9 Disconnect sampling equipment from reefer unit and replace all service valve caps.
- 4.10 Take sample to designated (well ventilated) test area.



Carrier Thin Line - Liquid line valve positioning

5 At the well ventilated test area – Sample testing.

- 5.1 Connect the capillary tube to the high pressure quick connector using a quick connector - 1/4" flare adapter (Mitsubishi part No. SSA327B047).
- 5.2 Place end of capillary tube into water filled container (approx 1/3 full) - Fresh water to be changed regularly and/or after a failed test.
- 5.3 Light halide torch and adjust to a small flame (a large flame is ineffective) – see figure 1 and appendix A.
- 5.4 Let torch stabilise until a clear blue flame is observed (minimum 1 minute).
- 5.5 Slowly adjust high pressure quick connector to regulate flow of sample gas so only a very small amount of gas is released, indicated by single gas bubble forming at the end of capillary tube seen in the water, breaking away and next bubble then forming. (If using dual-purpose rig fully open high pressure quick connector and slowly open in-line ball valve A so only a very small amount of gas is released). Refer to schematic 2.

Document No. EMS-03 Ver 2.1	Engineering & Maintenance Services, Seaco Global Ltd. 21 St Thomas Street. London SE1 9RY Tel: +44 (0) 20 7939 5600 Fax: +44 (0) 20 7939 5650 www.seacoglobal.com	8 of 25
--------------------------------	--	---------

- 5.6 Place halide torch search hose above the water directly over where the bubbles are breaking on the surface of the water (a water container with a narrow neck is recommended).
- 5.7 Observe halide torch flame colour in the burner for up to 1 minute.

This test will detect if there are chlorine contaminants in the sample/system (sensitivity 300ppm). R134a will not change the flame colour so it will remain blue. If the flame colour changes to green it indicates a presence of a chlorine contaminant.

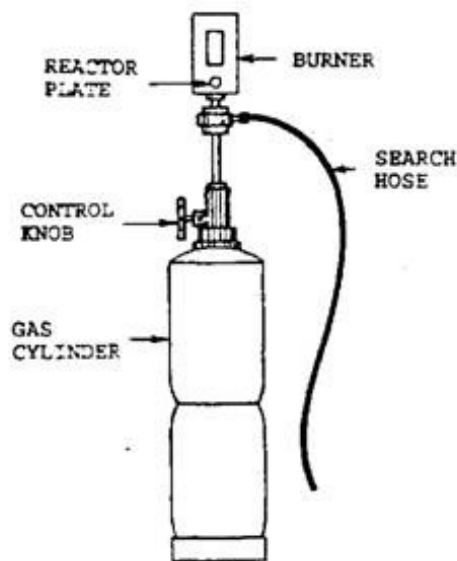

Figure 1 - Halide Torch

Ensure that the correct gas is used for the halide flame testing as per the manufactures instructions (propane)

<p>Document No. EMS-03 Ver 2.1</p>	<p>Engineering & Maintenance Services, Seaco Global Ltd. 21 St Thomas Street. London SE1 9RY Tel: +44 (0) 20 7939 5600 Fax: +44 (0) 20 7939 5650 www.seacoglobal.com</p>	<p>9 of 25</p>
--	---	----------------



Halide torch
flame

End of capillary
tube into water
filled container

Photo E - Example of test set-up using fume cupboard with extractor fan



Photo F - Example of test set-up using manifold gauge set

- 5.8 Steady blue flame, gas sample/system is ok - Recover and dispose of remaining refrigerant from the sample equipment and proceed to section 6.
- 5.9 If green in flame or a steady green flame, sample/system is contaminated – Shut all valves to retain remaining sample and proceed to section 6b.



6a Actions – Blue Flame (Pass) *see also note at the end of section 6 for the cleaning of rigs*

- 6.1. If steady blue flame is observed, & all else appears normal on the unit (oil / sight glass colour etc), the unit has passed the health check.
- 6.2. Record the results on the document provided and send to Seaco.
- 6.3. Apply 'Health Check' decal as provided by Seaco.
- 6.4. Where a health check decal has previously been applied, decal to be removed or new decal fitted over old.
 - Enter depot name
 - Location
 - Tick the appropriate box for the test / tests carried out
 - Date of test

Refrigerant Test Passed

Depot Name :

Location:

Date of Test :

Test Method: Halide flame test Tick appropriate box

RAE tube test

GCMS test

Electronic tester

Sample, refrigerant test pass decal



Apply refrigerant pass decal alongside the R134 refrigerant decal.

6b Actions – Green Flame (Fail)

- 6.5 Contact Seaco and / or refer to Seaco's Refrigerant Purity Check Procedure for Extracting Gas Sample For Analysis.
- 6.6 Container should not be connected to power.
- 6.7 Container should be moved /quarantined in a designated area
- 6.8 Do not fit refrigerant pass decal to a reefer that fails health check.
- 6.9 Unit to be marked **X at risk** by depot and Seaco to be advised of failure and serial number.
- 6.10 Where a contaminated sample has been extracted, the rig will need to be cleaned to ensure no cross contamination for the next sample, see note below

Note: Rigs will periodically need to be cleaned when either oil or liquid refrigerant has been extracted; this can be done by blowing clean compressed air and/or oxygen free (dry) nitrogen from bottle through the rig. In the case of a contaminated sample been extracted and to prevent cross contamination of the next sample the rig must be

Document No. EMS-03 Ver 2.1	Engineering & Maintenance Services, Seaco Global Ltd. 21 St Thomas Street. London SE1 9RY Tel: +44 (0) 20 7939 5600 Fax: +44 (0) 20 7939 5650 www.seacoglobal.com	13 of 25
--------------------------------	--	----------

cleaned by evacuation and flushing with oxygen free (dry) nitrogen until the rig is found to be clean and the test flame noted as blue

***Send data to local Seaco Depot Operations Manager (DOM) or contact local DOM for any matters relating to this procedure.*

As stated above, this document has been prepared for use only by suitably qualified and experienced engineers under proper supervision and direction from their own companies in relation to the routine extraction and testing of refrigerant gas from machinery in ISO shipping containers. It is for such persons and their employers to fulfill their own responsibilities as regards legal, environmental, health and safety or other like responsibility in or about conducting such processes. Seaco is not at any stage undertaking any role as legal or H&S advisor to any third party and this document or other communications with Seaco employees should not be relied on such. Seaco Global Ltd, its employees, agents, directors and related companies hereby disclaim any liability for injury, loss or damage of whatsoever nature and howsoever caused to the fullest extent permissible by law in relation to all matters set out herein. Seaco Global Ltd is the UK subsidiary of Seaco Srl, and in combination with their affiliated companies are container leasing company and not in the business of dispensing advice to third parties. Any person in need of advice should seek it from their own sources.

Appendix A - Halide Torch Test

This test will detect if there are chlorine contaminants in the sample/system (sensitivity 300ppm / 0.03%). R134a will not change the flame colour so it will remain blue. If the flame colour changes to green it indicates a presence of a chlorine contaminant.



The flame adjustment is very important. A large flame will result in less sensitivity. The unit will work only when the reactor tube is hot (minimum 1 minute) and the flame is adjusted correctly. After lighting, close the control knob (valve) very slowly while watching the flame in the burner (shroud).

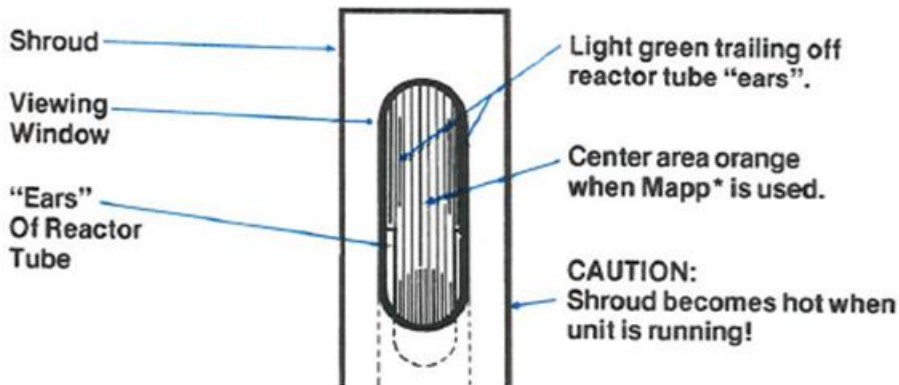
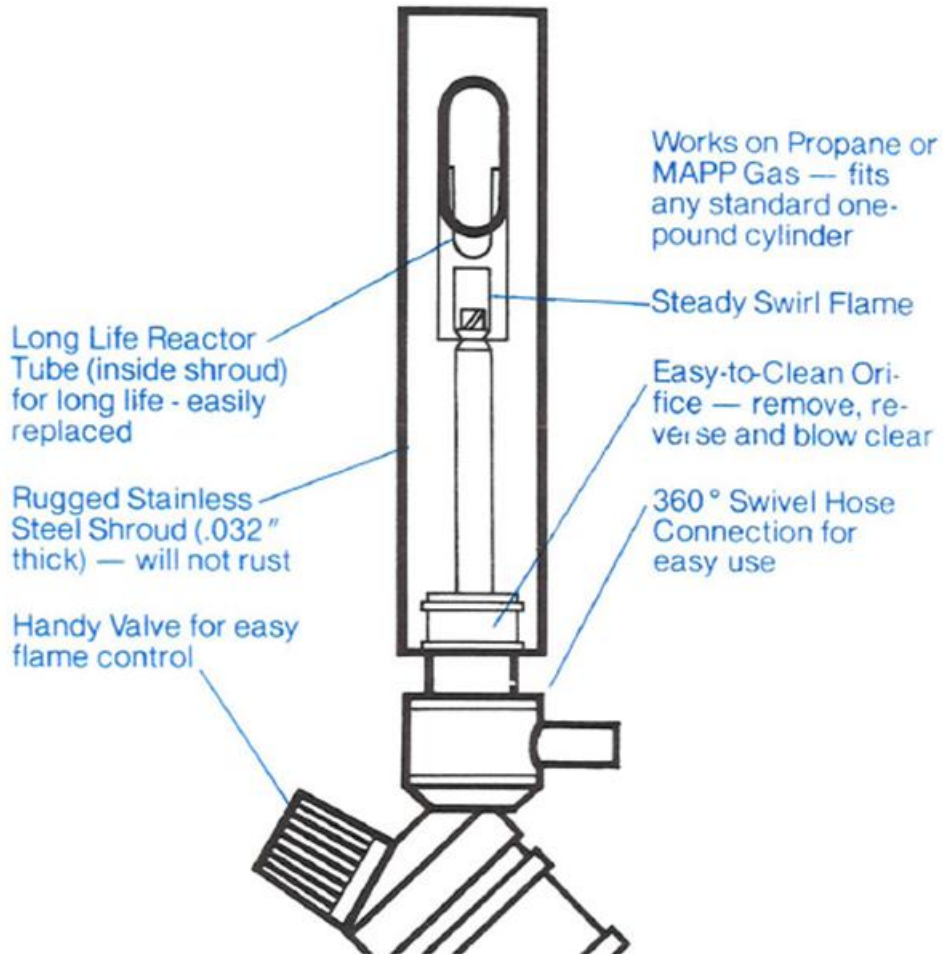

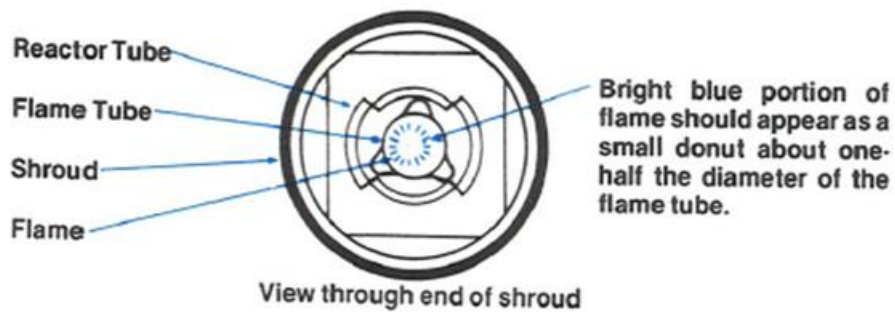
Document No. EMS-03 Ver 2.1	Engineering & Maintenance Services, Seaco Global Ltd. 21 St Thomas Street. London SE1 9RY Tel: +44 (0) 20 7939 5600 Fax: +44 (0) 20 7939 5650 www.seacoglobal.com	14 of 25
--------------------------------	---	----------









Appendix B - Tools / Parts List



S/N	Item	Photo	Quantity
1	Oxygen free (dry) nitrogen bottle with regulator (general use)		1
2	Vacuum pump (general use)		1

3	1 x 1/4" Flare Swivel Coupling. (Optional)		1
4	Compound gauge.		1
5	1 x 1/8" Female Briggs to 1/4" Male Flare Coupling.		1

6	1 x 1/4" Male Flare Sight Glass. (Optional)		1
7	R134a high pressure hose.		1 length (30 cm, 1 ft.)
8	R134a high pressure quick connector (with male flare connection for the hose to connect to)		1

9	1/4" female to R134a high pressure quick male connector. (e.g.: TK part No. 66-7179)		2
10	1 x 1/4" Male Flare Union Tee.		1
11	1 x 1/4" Female Flare Union.		1

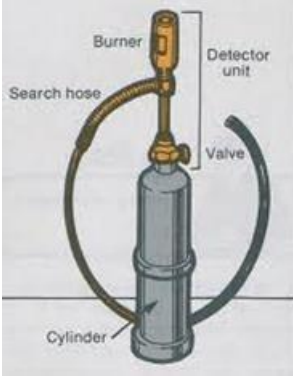
12	1 x In-Line Ball Valve - 1/4" Male to 1/4" Female Flare.		2
13	High pressure male quick connector to 1/4" male - Mitsubishi part No. SSA327B047		1
14	Capillary tube		1 length

15	Halide torch		1 set
16	Refrigeration ratchet spanner		1
17	Fume cupboard (installed with extractor fan)		1

18	Loctite 567 thread sealant		1
19	Water container/bottle		1

Appendix C - RAE Refrigerant Risk Assessment Test (RRA test)

The Refrigerant Risk Assessment Test (RRA) can be used to establish whether chlorides or R40 are present in the extracted sample. The Refrigerant Risk Assessment test can be used after the halide flame test has indicated the presence of chlorides; the Risk Assessment Test will confirm whether R40 present and / or other chloride contaminates.

For further information on the Refrigerant Risk Assessment Test or for the test equipment and test tubes used to establish the presence of R40 / chlorines, please contact RAE / Holland Reefer Service directly.

Web address: www.hollandreeferservices.nl

Contact details:

General: sales@hollandreeferservice.nl

For New Zealand and Australia: sales@pinnacle-corp.co.nz

For North America, Canada, and Central America: RRASales@cgini.com

Appendix D: Alternative rigs:

CONGLOBAL-GAS EXTRACITON AND ANALYSIS RECOVERY SYSTEM (C-GEARS)

The gauge and connector assembly consists of the following components:

- A. Acme (auto) adaptor to ¼" flare fitting
- B. ¼" flare female union
- C. Quick connect valve
- D. T- fitting ¼" flare
- E. ¼" flare adaptor to ¼" pipe thread (female)
- F. Low pressure refrigerant gauge (R134a)
- G. Low loss line 8" in length with ball valve, ¼" flare fittings
- H. Female ¼" flare adaptor to ¼" tubing
- I. ¼" copper tubing
- J. ¼" adaptor from tubing to capillary tube
- K. Capillary tube (0.054" inner diameter)
- L. Schrader adaptor (Thermo King Part #66-9873)
- M. Ball valve ¼" flare connections
- N. Double male ¼" flare connector

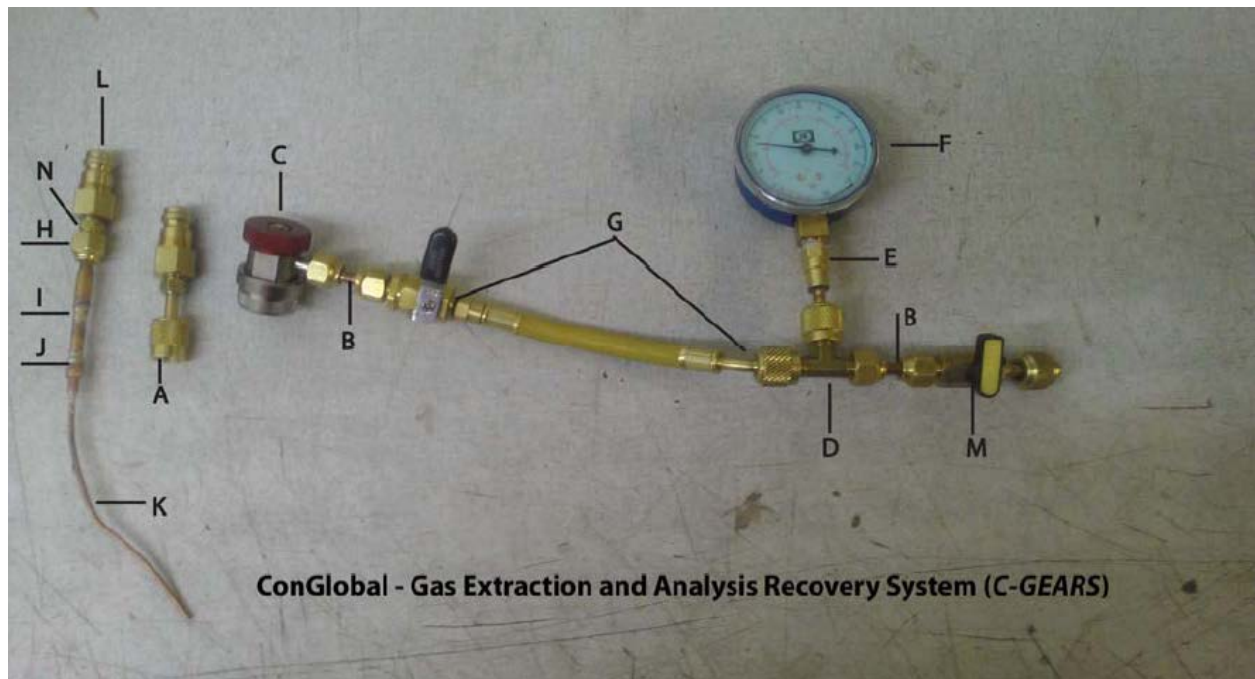

For further details contact: www.cgini or pyata@cgini

<p>Document No. EMS-03 Ver 2.1</p>	<p>Engineering & Maintenance Services, Seaco Global Ltd. 21 St Thomas Street. London SE1 9RY Tel: +44 (0) 20 7939 5600 Fax: +44 (0) 20 7939 5650 www.seacoglobal.com</p>	<p>23 of 25</p>
--	---	-----------------

Test rig and testing equipment and test tubes available from RAE through Holland Reefer services. Contact details below

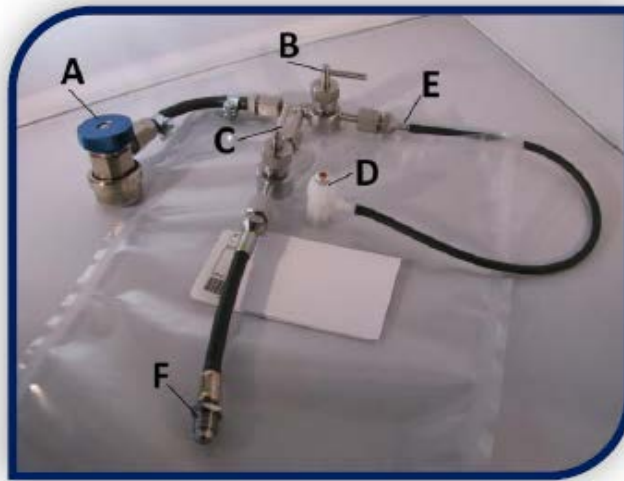

Test rig

Test tubes



No or minor discoloration; minimal or no contamination present in the refrigerant system.



Yellow discoloration; system contaminated with chloride, laboratory analysis is recommended.



Reddish brown discoloration indicates the likelihood of R40 and / or R142B. Laboratory analysis is highly recommended.

Further information for rig, test equipment and tests tubes by RAE is available from:

North America (USA and Canada), Central America (Mexico to Panama):
Con Global Industries - RRASales@cgini.com

Australia, New Zealand:
Pinnacle Corporation - sales@pinnacle-corp.co.nz

Other Regions:
Holland Reefer Service B.V. - sales@hollandreeferservice.nl